

- D** Montage und Betriebsanleitung
- USA GB** Assembly and Operating Instructions
- F** Instructions de montage et d'utilisation
- E** Instrucciones de uso y montaje
- P** Instruções de montagem e modo de utilização
- I** Istruzioni di montaggio e d'uso
- NL** Montage- en gebruiksaanwijzing
- S** Monterings- och bruksanvisning
- HUN** Összeszerelési és használati útmutató
- PL** Instrukcja obsługi i montażu

**Carrera**<sup>®</sup>

**GO!!!**

Stadlbauer Marketing + Vertrieb Ges.m.b.H.  
Magazinstraße 4 · 5027 Salzburg · Austria  
www.carrera-toys.com · www.carreraclub.com

**RALLY HEROES**

**60805**

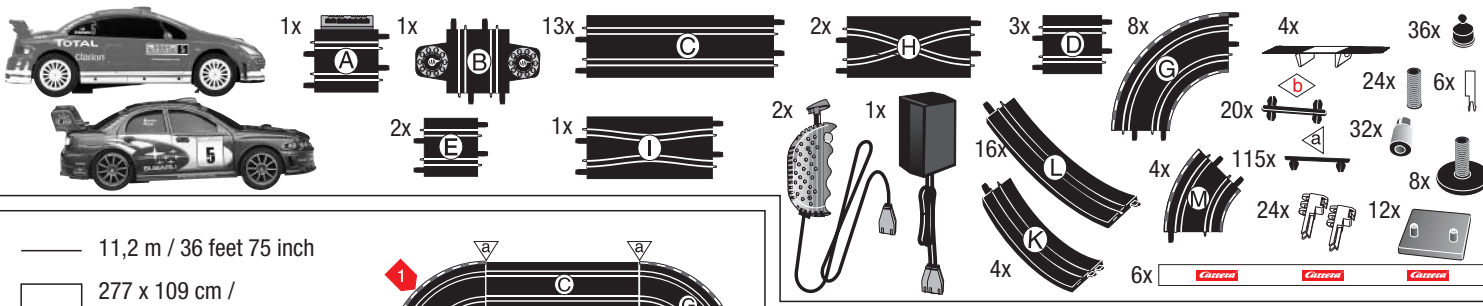

— 11,2 m / 36 feet 75 inch  
 □ 277 x 109 cm / 9.09 feet x 3.58 feet

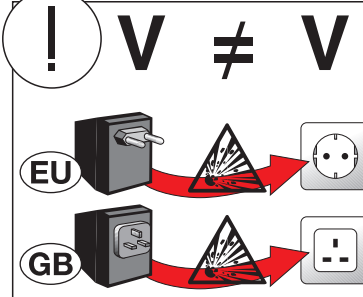
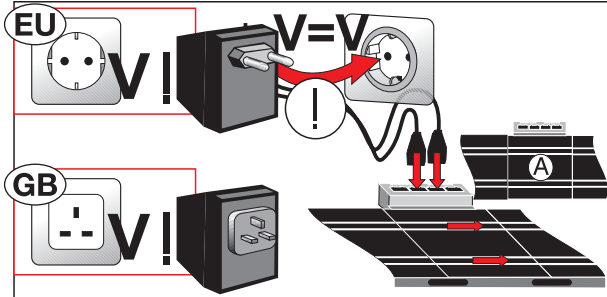
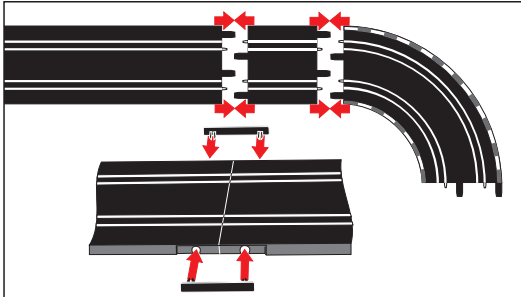
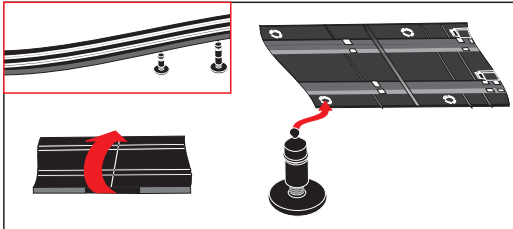
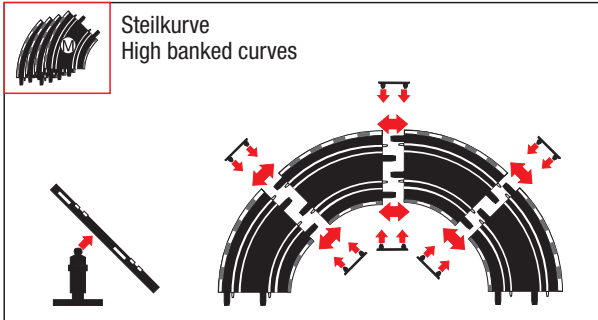
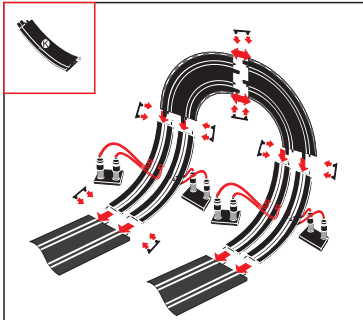
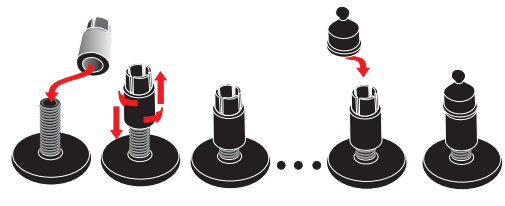
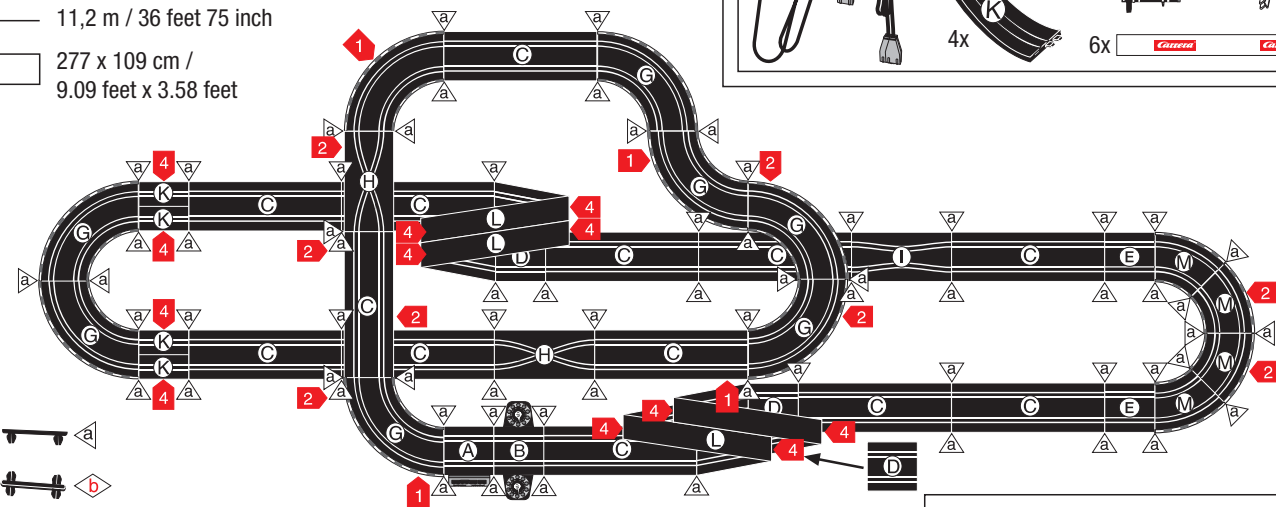

7.60.12.07.00

- D** Technische und designbedingte Änderungen vorbehalten.
- F** Sous réserve de modifications techniques ou de design.
- P** Reservados os direitos de alterações técnicas e no design.
- NL** Technische en designgeboden afwijkingen voorbehouden.
- HUN** Műszaki és konstrukciós változások előfordulhatnak.
- GB** Subject to technical and design-related changes.
- E** Se reserva el derecho de efectuar modificaciones técnicas y relacionadas con el diseño.
- I** Con riserva di modifiche tecniche e di design.
- S** Med reservation för tekniska och designrelaterade ändringar.
- PL** Zastrzegamy sobie możliwość zmian.



**AGE**  
**6+**

14,8V == 2 x 350 mA



**WARNING:**  
**CHOKING HAZARD-** Small parts.  
Not for children under 3 years.

